

**\*\*\*READ & SAVE THESE INSTRUCTIONS \*\*\***  
**ACCESS LIGHTING**  
**MODEL 50483**  
**INSTALLATION & OPERATION INSTRUCTIONS**

(1) TOOLS AND MATERIALS REQUIRED

- ❖ BLADE SCREW DRIVER
- ❖ WIRE CUTTERS
- ❖ WIRING SUPPLIES AS REQUIRED BY ELECTRICAL CODE

**Attention:**

*Before assembling your lighting fixture, please read the following instructions. If you feel you do not have sufficient electrical experience, refer to a do-it-yourself wiring handbook or have your fixture installed by a qualified licensed electrician.*

(2) GENERAL

1. To ensure the success of the installation, be sure to read these instructions and review the diagrams thoroughly before beginning.
2. All electrical connections must be in accordance with local codes, ordinances, or the National Electrical Code. If you are unfamiliar with methods of installing electrical wiring, secure the services of a qualified licensed electrician.
3. These fixtures are intended for mounting to a standard 4" x 2 ¼" deep metal octagon outlet box. The box must be directly supported by the building structure and U.L. Recognized.
4. Before commencing with the installation, **disconnect the power by turning off the circuit breaker** or by removing the fuse at the fuse box. Turning the power off using the light switch is not sufficient to prevent electrical shock.

**NOTE:**

*The important safeguards and instructions appearing in this manual are not meant to cover all possible conditions and situations that may occur. It must be understood that common sense, caution and care, are factors that cannot be built into any product. These factors must be supplied by the person(s) caring for and operating the fixture.*

(3) UNPACKING THE FIXTURE

On checking the contents of the box you will find;

- ❖ Mounting Hardware
- ❖ Fixture Assembly
- ❖ Glass Diffuser
- ❖ 1 x 100W/HGN/120V/ J7 8mm Bulb

(4) PREPARE THE FIXTURE

Refer to attached illustration of fixture parts and assembly.

1. If you are replacing an existing fixture disconnect and remove the old fixture. Expose the supply wiring from the outlet box.
2. Attach the **Crossbar** to the junction box with the supplied **Mounting Screws (1)**.
3. Attach the **Supply Wires** to the **Fixture Wires**:  
The **Black supply wire** attaches to the **Black fixture wire** and the **White supply wire** attaches to the **White fixture wire**.
4. Attach the **Green/Ground wire** from the fixture to the **Electrical Supply Wire** or to the **Green Screw** located on the **Mounting Plate**. Secure these connections with supplied **Wire Nuts (2)** and tape these connections with electrical tape. Tuck wires carefully into Junction box.
5. Position the crossbar with the **Fixture Back plate**, secure with the **Screws (3)**.
6. Position the **Glass Diffuser (4)** on the **Fixture plate** and secure the **Thread Rods(5)**.
7. Insert the **1 x 100W/HGN/120V/J78mm Bulb (6)**.  
**DO NOT EXCEED WATTAGE SPECIFIED ON WARNING LABEL**
8. Place the **Bulb cover (7)** onto the Socket.
9. Position the **Cover Plate (8)** onto the **fixture plate** and secure with the supplied **Knobs (9)** .
10. Restore electricity and check the operation of your new lighting fixture.

**CAUTION:**

- **Ensure that the Fitting is Cool and Switched off, Before Changing the Bulb.**
- **Do Not use Bulbs Exceeding Maximum Wattage, As Per Caution Label.**
- **Do not Handle the Bulbs with Bare hands. Use a soft Cloth.**
- **Do not place fixture on or near combustible material.**

**a c c e s s**

**L I G H T I N G**

# MODEL 50483

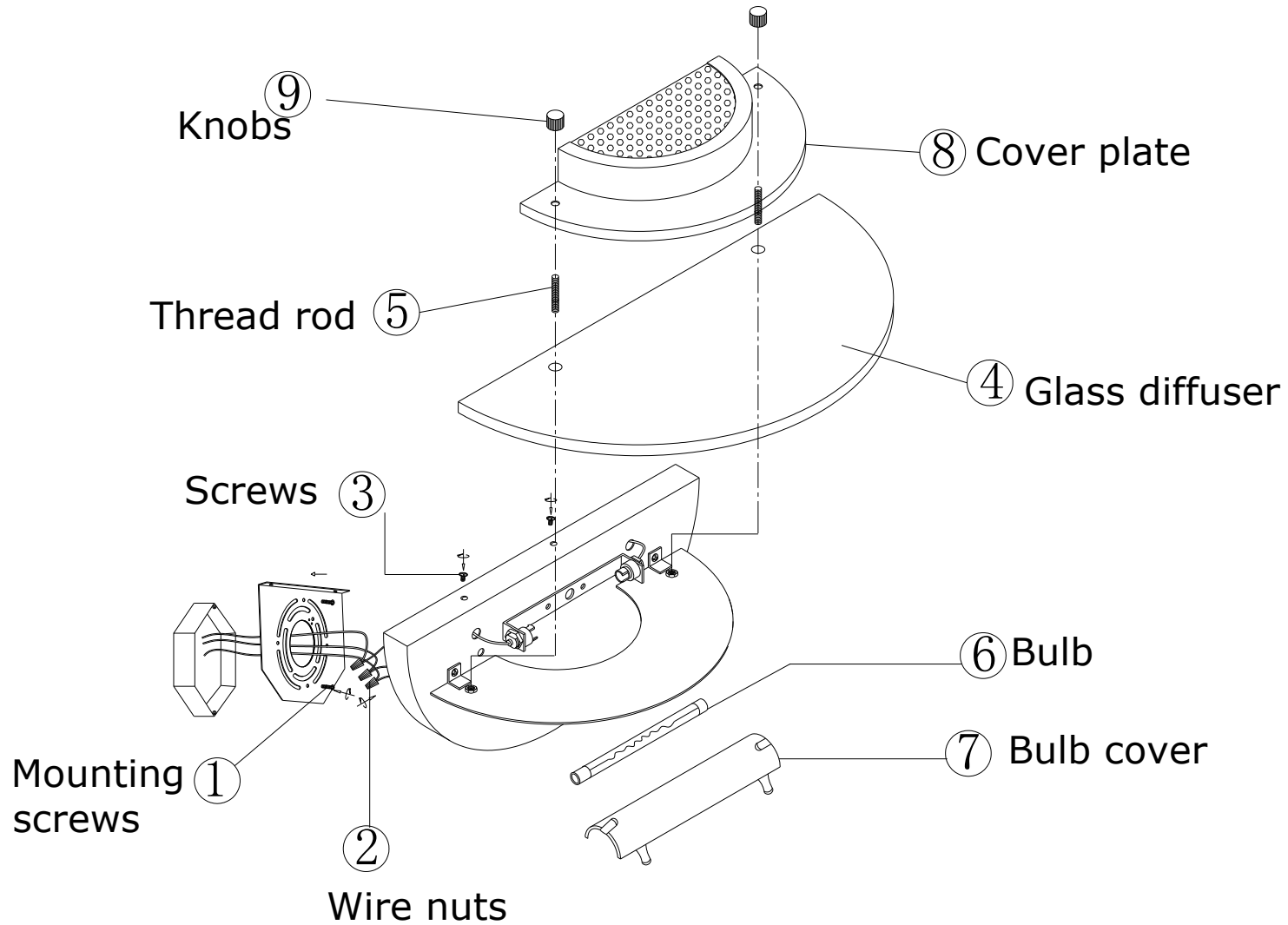

**a c c e s s**

L I G H T I N G